



# Textbook Elevating Work Platform Safety



**NoRisk**

Schurinkstraat 22b  
7731 GD Ommen  
0529 820210 | [info@nrvo.nl](mailto:info@nrvo.nl)

[www.noriskveiligheidsopleidingen.nl](http://www.noriskveiligheidsopleidingen.nl)



# Textbook

## Elevating Work Platform Safety



## QUIZ

<https://www.noriskveiligheidsopleidingen.nl/quiz/>

# 1. Working Conditions Act

1.1

## **Introduction**

All employees are affected by working conditions, regardless of the work they do. Working conditions is an umbrella term for all matters related to health, safety and wellbeing at work. All measures taken to promote safety, health and wellbeing are based first and foremost on the Working Conditions Act.

1.2

## **Structure of Working Conditions legislation**

The Working Conditions Act is a framework and does not stipulate any specific rules. Rather, it contains a general description of duties and obligations relating to safety, health and wellbeing at work. The Working Conditions decree sets out the rules about the most common workplace risks in greater detail.

The Working Conditions Regulations contain even more detailed regulations on subjects such as the reporting of accidents, occupational diseases and occupational health and safety services.

*The core principle behind the Working Conditions act is that employees and employers share responsibility for working conditions.*

1.3

## **Occupational health and safety data sheets (AI sheets)**

These so-called 'authoritative publications' are intended to flesh out the Act, but they do not belong to the Act proper, unless they are referred to explicitly in the Act.

Examples include:

- AI - 1 Occupational health and safety and absenteeism policy;
- AI - 11 Shielding and protecting machines;
- AI - 14 Business premises - layout, transport and storage;
- AI - 17 Hoisting and lifting equipment and safe hoisting.



1.4

## **Occupational Health and Safety service**

Companies are no longer obliged to register with an Occupational Health & Safety (OHS) service, although it is still mandatory to seek expert support and advice, where necessary. This role can be played by an internal or external competent OHS expert.

This amendment to the Working Conditions Act is intended to give branches and companies more freedom of choice in the area of working conditions and absenteeism prevention. In order to guarantee the availability of absenteeism counselling and to give employees the opportunity to visit an OHS consultation hour, suitable arrangements must be made or a contract must be concluded with a registered occupational health physician.

## 1.5

### **Netherlands Labour Authority (NLA)**

The Netherlands Labour Authority (NLA) falls under the purview of the Minister of Social Affairs and Employment. And it informs, monitors, inspects and, if necessary, obliges employers and employees to improve their arrangements for health and safety. If an employee or employer violates the regulations, the Netherlands Labour Authority (NLA) is authorised to impose a fine. In addition, the Netherlands Labour Authority (NLA) stimulates consultation and coordination between employees and employers. The Netherlands Labour Authority (NLA) investigates the causes of accidents and advises the Minister on additional laws and/or policy regulations.



Nederlandse Arbeidsinspectie  
Ministerie van Sociale Zaken en  
Werkgelegenheid

Netherlands Labour Authority (NLA) inspectors have the authority to impose an administrative fine if they establish that the Working Conditions Act has been violated. The Ministry of Social Affairs and Employment publishes an annual list of all violations and the associated fines, as part of its immediate-response policy (Dutch: Lik-op-stuk-beleid), which has been in place since 1 November 1999.

## 1.6

### **Rights and obligations**

Employers must take measures to optimise their employees' safety, health and wellbeing and align this policy with all other policies in effect within the company.

### 1.6.1

#### **For employers**

Despite the fact that the Working Conditions Act is a list of general requirements, several clear obligations for employers arise from it:

- Employers must establish good working methods (through work instructions) and provide Personal Protective Equipment (PPE);
- Employers must ensure the workplace features escape routes and first-aid equipment;
- Employers must provide workers with adequate information on and training for the work they have to do;
- Priority must be given to new employees and the employees who are most at risk;
- Employers and employees must have regular meetings;
- Employers must, as far as possible, avoid giving employees monotonous, machine-based work (e.g. assembly line work);
- Employees must give employees the opportunity to maintain or improve their skills.
- Employers must adapt the situation at work (e.g. workplace layout or working methods) to their employees as much as possible;
- Employers must give employees as much freedom as possible in deciding how to do their work;
- Employers must take into account the personal characteristics of employees, such as age, education, experience and their physical and mental condition.  
In short: they have to make sure the right person is in the right position;
- Employers are obliged to describe their OHS policy and all risks present in their company in an RI&E. In addition, employers are obliged to describe all situations that do not meet the requirements set in the Act in an Action Plan;
- Depending on the nature of their company, employers must be assisted by one or more qualified Emergency Response Officers (EROs);
- Employers must implement an absenteeism policy.

1.62

### For employees

The Working Conditions Act also imposes various obligations on employees.

Employees also have various general obligations, such as:

- Employees must carry out the work in such a way that they do not endanger themselves or others;
- Employees must be familiar with procedures and instructions and act accordingly;
- Employees must use machines, equipment and the safety devices attached to them correctly;
- Employees are obliged to use personal protective equipment (such as a safety helmet, gloves, shoes and goggles) and to maintain it properly;
- Employees must participate in organised instruction and information sessions provided by the employer;
- Employees must report dangerous situations to the person in charge.

1.7

### CE - marking

On 1 July 1995, the European Union introduced a law to ensure that machines can be used safely. This law, the so-called Machinery Directive, lists a range of criteria that new products must meet. If a new product meets the requirements set out in this Machinery Directive, the manufacturer can affix CE marking to its product and issue a corresponding EC declaration of conformity. CE stands for Conformité Européenne. It is up to manufacturers to establish that the technical solutions they have developed meets the minimum requirements set out in the Machinery Directive. Products that pose serious risks, such as terminal trucks, require an official inspection report issued by an accredited inspection company.



1.8

### Risk Inventory & Evaluation ( RI&E )

The rules specified in the Occupational Health & Safety Act are intended to ensure that employees can work safely and healthily in a pleasant atmosphere. All companies must draw up an Occupational Health & Safety (OHS) policy, indicating their arrangements for occupational health and safety and specifying whether they are willing to make funds available for this purpose. Working safely is often difficult in practice.

There is always a chance that something will go wrong, and that is what we call risk. The definition of risk is as follows:

i

#### NOTE

**Risk is the degree of probability that a certain undesirable effect will occur.**

**In summary: Risk = Probability x Effect.**

The law requires employers to carry out a risk analysis, the so-called RI&E, with the assistance of one or more expert employees. If an employer does not have any or enough of these employees, external experts must be hired for this purpose. This written analysis focuses on two main points:

- The degree of probability (the chance) that an accident will or could occur.
- The consequences of the accident, should it occur, in the short and/or long term.

During the risk analysis, the expert investigators identify the risks in the workplace and assess them on the following points:

- *Nature of the work;*  
Office workers run different risks than transport workers.
- *Training;*  
Employees without the right training are at greater risk than those with the right training.
- *Workplace;*  
Employees must not be able to stumble or slip easily.
- *Well-being;*  
Employees must be able to enjoy their work.

You have to know the risks before you can do something about them and reduce or even eliminate the risk of an accident. When an unacceptable risk is identified, employers must take measures, such as the following:

- Stop the work and provide instructions: in some cases, employees may be unaware that they are doing something wrong.
- Modifying the unsafe workplace;
- Training employees;  
Providing proper instructions reduces the likelihood that an accident will happen.

This results in reduced risk. Reducing risk is in the employer's and the employee's best interest, which is why the RI&E and the associated Action Plan must be known to the employees concerned.

---

i

**NOTE**

**The Action Plan indicates what will be done to address any remaining problems and when this will happen.**

Every year, a written evaluation must show whether the current workplace situation still corresponds to the RI&E and Action Plan. Because the RI&E is the source document for the OHS policy, it must be assessed by certified experts. Employees are permitted to do so themselves, provided they have certified experts or an internal OHS service at their disposal. In other situations, they must call in external certified experts.

As of 1 April 2012, companies with a maximum of 25 employees need not have their RI&E document inspected, provided that they use a recognised RI&E instrument.

---

i

**NOTE**

**Remember that there is a lot you can do to prevent accidents yourself. A good approach starts with assessing the risks that go along with your work.**

## 2. Elevating work platforms & types

21

### Introduction

There are various ways to work at height: you can use scaffolding, a ladder, or an elevating work platform (EWP), with the latter often being considerably more versatile than the others. This textbook is all about elevating work platforms.

In order to prevent accidents, it is important that you have been thoroughly instructed on the safe and proper use of an EWP. You need to know which rules to follow and how to apply them in practice.

i

### NOTE

This coursebook is not big enough to discuss all EWPs out there. Different EWPs may be operated and work in different ways. It is important to always read the user manual of the EWP you are about to use before you start working with it.

22

### Types of elevating work platforms

European Standard EN 280 specifies the requirements that an EWP must meet and defines an EWP as follows:

An elevating work platform is a mobile lifting device featuring one or more moving lifting surfaces, designed to move people or equipment.

The EN 280 European Standard distinguishes between three categories of EWPs:

- Category 1B Static boom lifts
- Category 3A Mobile vertical lifts
- Category 3B Mobile boom lifts

In the following sections, we will discuss the various categories and their specifications in greater detail.

EWPs are used to lift people up to a certain height, so that they can carry out their work. In some cases, it will be necessary to bring equipment or materials with you, such as tools, but keep in mind that an EWP is not a goods lift!



23

Elevating work platforms consist of three main components

#### Platform

The platform is a fixed component of EWPs that is used to support people while raising and lowering the lifting mechanism. People stand on the platform while carrying out their work. In some cases, the work platform may be movable. Scissor lifts, for instance, may feature an extendible platform. On rotating lifts, the platform can be moved to the side of or under the chassis.

#### Lifting system

Elevating work platforms can feature various lifting systems, such as scissor mechanisms, telescopic booms, and articulating booms.

#### Undercarriage

Undercarriages come in various shapes and sizes. Some undercarriages are mounted on the chassis of a truck or trailer, for instance. These EWPs are known as towed vehicles. Other undercarriages have their own drive system and are called self-propelled vehicles.

24

#### Category 1B static boom lifts

Static lifts are secured in place with outriggers. These outriggers prevent the lift from falling over. You cannot use this type of lift if it does not have outriggers. These lifts cannot be moved during work at height. On top of that, they can be equipped with various different drive systems.



**Trailer lift**

An elevating work platform mounted on a trailer that features outriggers is called a static lift. Static lifts come with either telescopic booms or articulating booms.

i

**To transport a trailer lift, you must have your BE driving licence. If you have a BE driving license, the trailer lift may not weigh more than 3500 kg.**

**Advantages and disadvantages of a trailer lift****Advantages:**

- + Highly mobile, can be transported by car
- + Quick to move from one location to the next
- + Very low weight

**Disadvantages:**

- Must feature outriggers
- Limited lifting capacity
- Wide
- Outriggers must be deployed prior to use

**Vehicle-mounted lift**

EWPs mounted on trucks or vans are also known as vehicle-mounted lifts. Again, a distinction can be made between telescopic and articulating booms.

There are large and small vehicle-mounted lifts. To operate a lift mounted on a truck, you must have a C-class driving license. For smaller versions, you may only need a B or BE-class driving license.

**Advantages and disadvantages of a vehicle-mounted I****Advantages:**

- + Can reach great heights
- + Have a large outreach
- + No need to arrange transport

**Disadvantages:**

- Special driving license required in some cases
- Only suitable for use on paved surfaces
- Outriggers must be deployed prior to use.

### Spider lifts

When you need to carry out work in a poorly accessible location or above a poor work surface, a spider lift with crawlers and outriggers can be a great solution. Spider lifts are driven to the right location by remote control.

Spider lifts can have a combustion engine, an electric motor, or a combination of both. In the case of the latter, the combustion engine is used to move the device to the intended location, while all other functions are powered by the electric motor.

### Advantages and disadvantages of a spider lift

#### Advantages:

- + Very compact
- + Highly manoeuvrable
- + Very stable
- + Suitable for uneven surfaces

#### Disadvantages:

- Lower lifting capacity
- Can only be used for light work
- Takes extra time to move
- Protruding outriggers.



### Self-propelled mobile vertical lifts 3A

Self-propelled lifts can be moved while the platform is in the :  
propelled mobile vertical lifts because they have their own drive mechanism.



**Scissor lift**

On a self-propelled scissor lift, the work platform is mounted on top of the scissor mechanism. The work platform can be raised vertically and will always remain in a straight line above the undercarriage. There are two types of scissor lifts: X-type and Z-type.



X-type



Z-type

**Advantages and disadvantages of a scissor lift****Advantages:**

- + Large work surface
- + Self-propelled
- + Large lifting capacity
- + No protruding outriggers

**Disadvantages:**

- Limited range
- Limited power
- Little or no outreach
- Must be transported

On many scissor lifts, part of the work platform can be extended or unfolded, creating a larger workspace. However, it is important to remember that increasing the size of the work platform will reduce the overall lifting capacity of the lift.

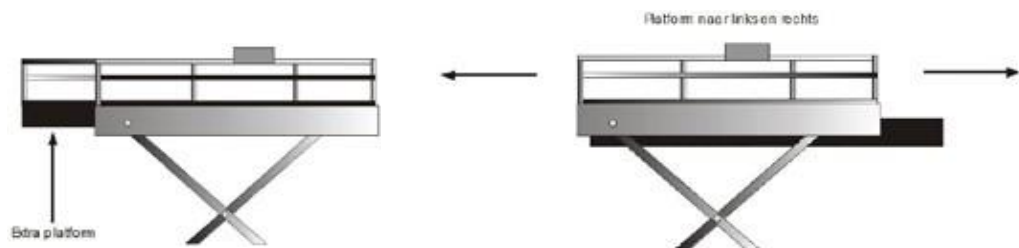

**Self-propelled single-person mast lift**

A self-propelled mobile single-person mast lift is a lift that can be operated by one person. Compact single-person mast lifts make it possible to work very efficiently at height. A very popular example is the JLG Toucan.

These self-propelled single-person mast lifts are very compact and can easily be transported in an elevator or van.

Thanks to their light weight and large range, these single-person lifts are extremely suitable for maintenance or inspection work and eliminate the need for ladders or stairs.

These self-propelled single-person mast lifts also come without a drive unit, which can be moved manually.

**Advantages and disadvantages of mast lifts****Advantages:**

- + Compact
- + Lightweight
- + Self-propelled

**Disadvantages:**

- No outreach
- Limited lifting capacity

**2.6 Mobile boom lift 3B.**

We can distinguish between two types of mobile boom lifts:



Telescopic boom



Articulating boom

## 26.1

### Mobile telescopic boom lift

The work platform of a mobile telescopic boom lift is supported by one or more boom segments. These segments can be extended to the desired height.

Telescopic boom lifts consist of five main parts:

1. The undercarriage
2. The superstructure
3. Extendible boom with or without jib.
4. Basket
5. Control panel at ground level or at height

### Advantages and disadvantages of a telescopic boom lift

#### Advantages:

- + Wide range in all directions
- + Self-propelled

#### Disadvantages:

- Small basket compared to a scissor lift
- Limited lifting capacity
- Heavy
- Has to be transported on a low-loader or semi-trailer



## 26.2

### Advantages and disadvantages of an articulating boom lift

Self-propelled articulating boom lifts have a so-called knuckle boom. These machines feature multiple cylinders, one of which is responsible for raising and lowering the first arm/boom. The second cylinder is used to lower the second arm/boom and is often attached to the telescopic boom, which can be extended and retracted. The machine may also feature another cylinder to move the jib, the small, secondary arm attached to a boom.

There are different types of articulating boom lifts, some of which can even reach heights of 47 metres. Articulating boom lifts differ from telescopic boom lifts in that their boom consists of multiple segments, allowing for a greater range of movement without having to move the undercarriage.

In practice, it is important to bring the lower boom in position first. You can then use the second boom to reach the desired working height.

## Advantages and disadvantages of a telescopic boom lift

### Advantages:

- + Very versatile
- + Wide range in all directions
- + Self-propelled

### Disadvantages:

- Small basket compared to scissor lift
- Limited lifting capacity
- Heavy
- Has to be transported on a low-loader or semi-trailer



27

### Choosing an elevating work platform

When choosing an EWP, it is very important to choose the right type with the right control mechanism. This depends on the nature of the work you are looking to perform, as well as the location of the work and the desired height.

Before choosing an EWP, there are a few things you have to know. To make this decision, you must know exactly what you want the EWP to be able to do and under what circumstances you will be using the EWP, as this will let you determine which type of EWP is suitable for the work you have to perform.

There are four questions to ask when picking an EWP:

1. How should it perform?
2. In what circumstances do you want to use the EWP?
3. Are there any limitations or restrictions?
4. What is the maximum cost?

27.1

### Choosing an elevating work platform

**Working height:**

What height does the EWP have to reach?

**Outreach:**

How far from the centre of the machine is the workplace?

**Articulation height:**

Are there any obstacles that would necessitate an articulating boom?

**Platform size:**

How many people have to work at height at the same time, how big is the equipment that has to be lifted up?

**Lifting capacity:**

What total weight will have to be lifted (persons and supplies)?

272

**In what circumstances do you want to use the EWP?**

**Inside or outside:**

Not all EWPs are suitable for indoor or outdoor use. This depends on various factors, including the EWP's power source and sensitivity to wind, and the surface on which the EWP is to be used.

**Subsurface:**

Will you be using the EWP on a flat surface or on an unpaved and/or uneven surface?

**Circumstances:**

Will you be working with corrosive chemicals or fine particles (e.g. sandblasting)?

**Usage:**

Will the EWP stay in the same spot for an extended period of time or will it regularly have to be transported over longer distances?

**Duration:**

Will the EWP be used for extended periods of time or in short bursts?

273

**Are there any limitations or restrictions?**

**Width or height restrictions:**

Height of doors, width of passageways.

**Weight restrictions:**

What is the maximum weight that the work floor or subsurface in question can bear? Sometimes, it can be wise to request a utility location plan or digging permit to see whether there are any cables or pipes underground.

**Power source:**

Exhaust fumes and noise.

274

**What is the maximum cost?**

Costs savings should never be a reason to compromise on safety.

i

**NOTE**

**When carrying out work such as spray-painting, sand-blasting or any work involving chemicals, this must be explicitly reported. When using a EWP for such work, you must first request written permission from the rental company.**



## 3. User responsibilities

3.1

### Introduction

EWPs are devices used to perform work or inspections and may therefore only be operated and serviced by trained personnel. In this section, we will discuss the responsibilities of anyone using an EWP.

3.2

### User responsibilities

The user of an EWP must be aware that they are responsible for the EWP and are authorised to stop the machine in the event of a malfunction or any unsafe situation caused by the machine or the work environment.

3.3

### Preparation, inspection, and maintenance

#### Preparations:

Before an operator starts using an EWP, they must have first read the user manual for the EWP in question. A user manual must be available for the EWP either in a physical or digital format.

#### Pre-work inspection:

Before you start using an EWP, you must perform a daily inspection. This is mandatory. By checking and inspecting the machine, you can be sure that it is safe to use. This is important, because you are partly responsible for the status of the machine.

#### The following must be checked:

##### Leaks:

Check all surfaces for oil, fuel, or battery fluid leaks and foreign objects. Report any leaks to your supervisor immediately.

##### Frame and mechanism:

Check the machine's frame for dents, damage, cracks in welds, and other imperfections.

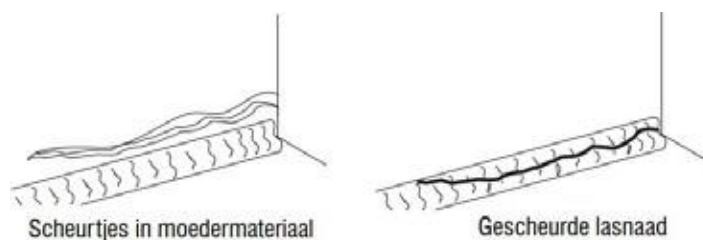

#### Stickers and plates:

Make sure that all stickers and plates are clean and legible. Make sure that there are no stickers or plates missing. Make sure to clean or replace any illegible stickers or plates.

#### Operating and Safety Manuals:

Make sure that the EWP is accompanied by a copy of the operating manual and user manual, either in a physical or digital format.

#### Inspection:

Inspections should be performed at least once a day and whenever the EWP is handed over to another user. The new user will then be responsible for the condition of the EWP. For more information about the inspection, please go to section 3.4.

#### Battery:

Recharge the battery where necessary and check whether there is sufficient demineralised water in the cells.

#### Fuel:

For machines with a combustion engine, check that there is enough fuel in the tank and refuel if necessary, making sure to use the right kind of fuel.

#### Engine oil (if any):

Check that the engine oil level reaches up to the Full mark on the dipstick and screw the cap back on.

#### Hydraulic oil:

Check the hydraulic oil level with a dipstick, the liquid-level gauge, or the indicator lines on the hydraulic oil tank. Make sure to top up the hydraulic oil when necessary.

#### Accessories and attachments:

Refer to the operating and safety manual of each attachment or accessory installed on the machine for specific instructions on inspection, operation, and maintenance.

#### Systems check:

After completing the inspection, all systems must be checked in a suitable location, where there are no obstacles on or above the ground.

### Example inspections per category

- Category 1B Static boom lifts
- Category 3A Mobile vertical lifts
- Category 3B Mobile boom lift

3.4.1

Static boom lift (1B)

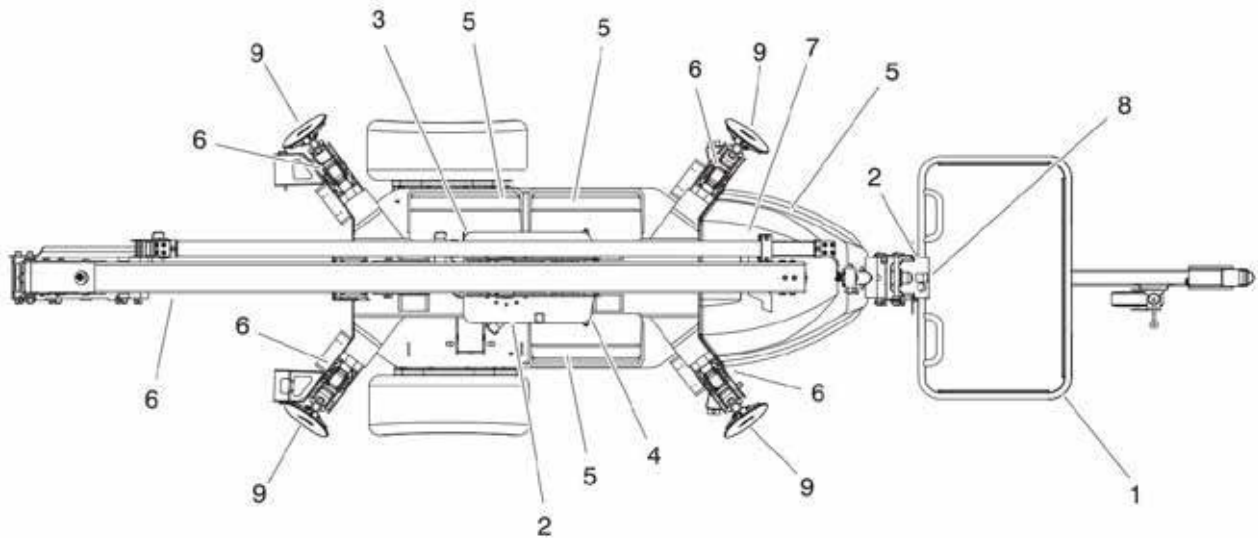

- |                                       |                                |
|---------------------------------------|--------------------------------|
| 1. Platform and railing               | 6. All hydraulic cylinders     |
| 2. Platform and ground controls       | 7. Hydraulic main pump         |
| 3. Boom segment/turntable             | 8. Platform rotation mechanism |
| 4. Swivel drive and turntable bearing | 9. Outriggers                  |
| 5. Covers                             | 10. Fifth wheel tow hitch      |

3.4.2

Mobile vertical elevating work platform (3A)

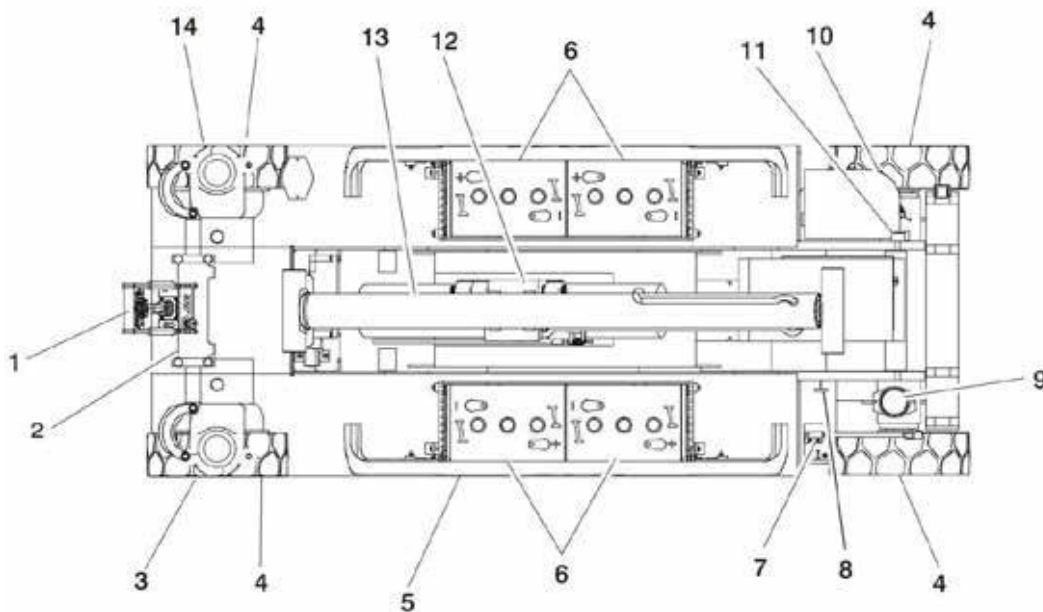

- |   |   |
|---|---|
| 1. Platform controls                              | 9. Flashing light                                   |
| 2. Steering cylinder                              | 10. Ground control station                          |
| 3. Left front Spindle, Track rod, and Drive motor | 11. Rotary switch                                   |
| 4. Wheels with tyres                              | 12. Hydraulic pump/motor                            |
| 5. Pothole protection system                      | 13. Lifting cylinder.                               |
| 6. Batteries and battery fluid                    | 14. Right front Spindle, Track rod, and Drive motor |
| 7. Proximity switch                               | 15. Scissor arms                                    |
| 8. Emergency descent system                       | 16. Platform/handrail (not shown)                   |

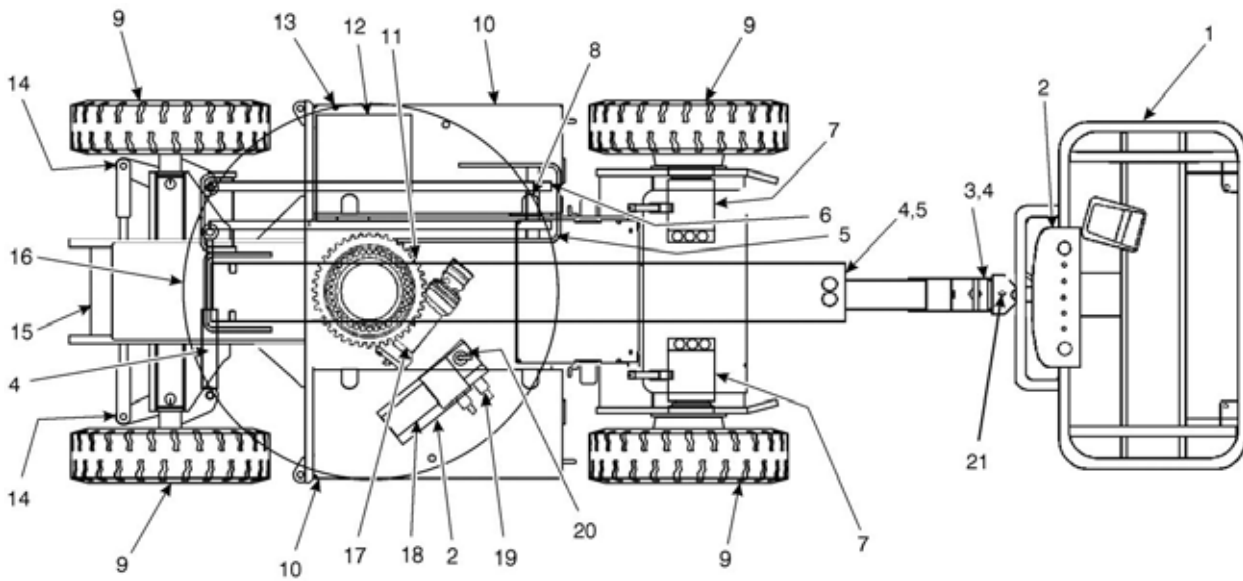

- |  |                                       |
|--|---------------------------------------|
| 1. Platform and railing                                | 12. Hydraulic oil pump                |
| 2. Platform and ground-level control console           | 13. Hood and lock                     |
| 3. Tip of extendible boom segment and platform support | 14. Track rod ends and steering axles |
| 4. All hydraulic cylinders                             | 15. Frame                             |
| 5. Secondary cylinder                                  | 16. Counterweight                     |
| 6. Boom segment/Raised lip/Turntable                   | 17. Swivel motor and worm gear        |
| 7. Limit switches                                      | 18. Battery charger                   |
| 8. Drive motor brake and hub                           | 19. Control valve                     |
| 9. Hydraulic Filter compartment                        | 20. Valve for manual lowering         |
| 10. Battery compartment                                | 21. Jib (not all types)               |
| 11. Turntable bearing                                  |                                       |

### 35

#### Controls and indicator lights

All machines feature control panels with symbols that show the various functions of the machine. In this section we will discuss examples of the three categories below.

- Category 1B Static boom lifts
- Category 3A Mobile vertical lifts
- Category 3B Mobile boom elevated working platform

**i**

#### NOTE

Indicator panels feature different types of symbols to alert the user to various situations that may arise. The meaning of these symbols is explained below.



Indicates a hazardous situation which, if not corrected, could result in death or serious injury. The indicator is Red



Indicates an abnormal situation which, if not corrected, could damage the machine or cause it to stall. This indicator is Yellow



Indicates important information about the machine's status, i.e. essential procedures for safe operation. The indicator is Green

### 3.5.1

### Static boom lift( 1B)

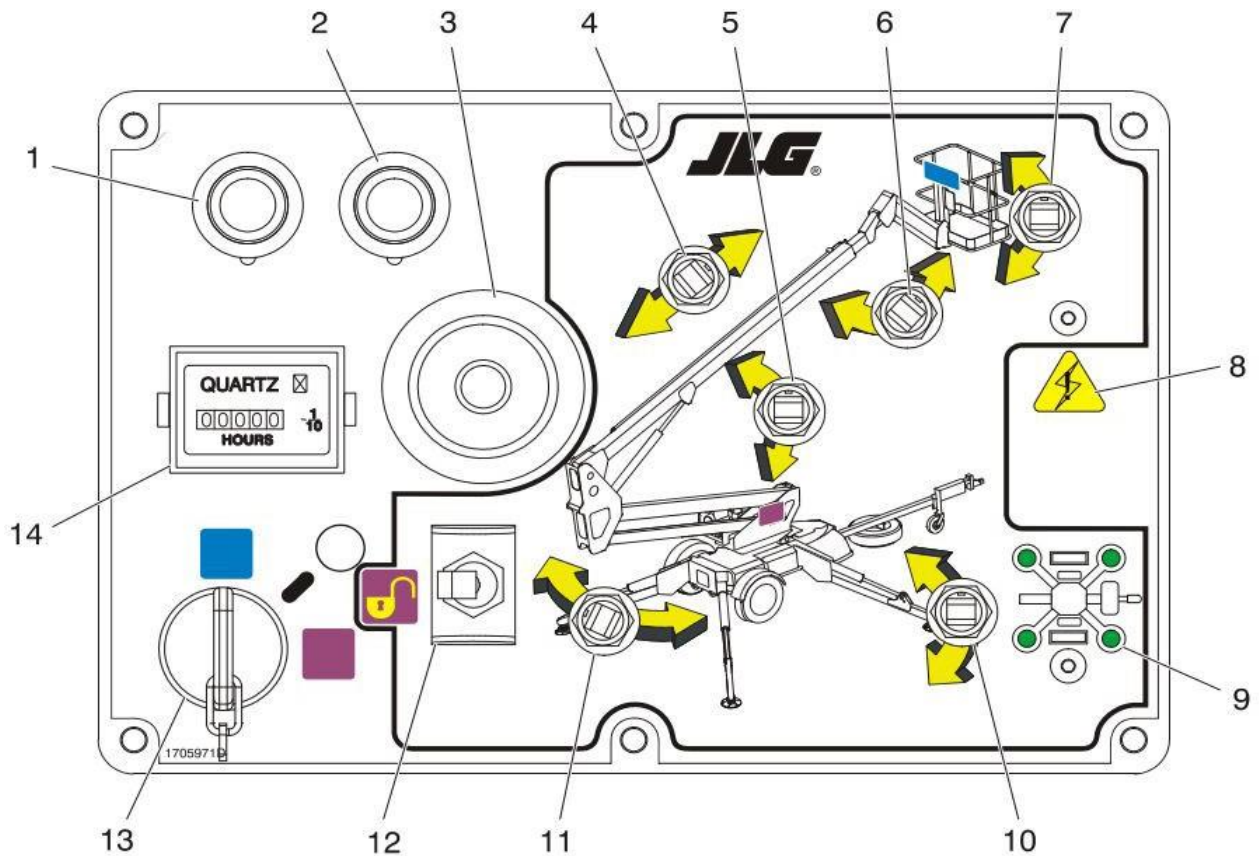

- |                                     |                                     |
|-------------------------------------|-------------------------------------|
| 1. Start                            | 8. System malfunction               |
| 2. Choke                            | 9. Outrigger indicator              |
| 3. Power supply /<br>Emergency stop | 10. Outrigger controls              |
| 4. Retract-extend                   | 11. Swivel                          |
| 5. Raise - lower                    | 12. Function activator              |
| 6. Raise jib                        | 13. Platform/Ground selector switch |
| 7. Level platform                   | 14. Hour counter                    |

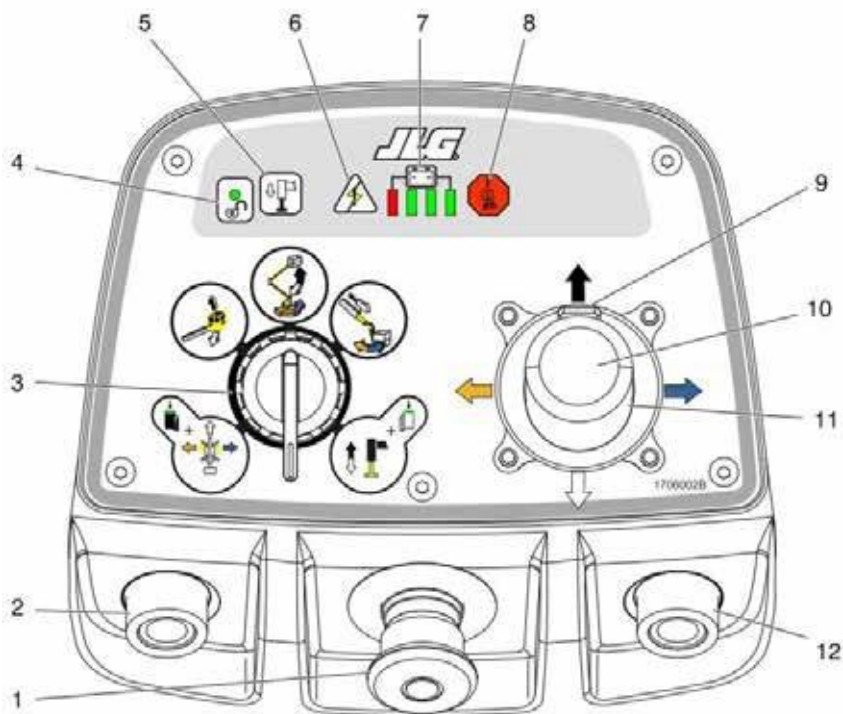

- |                                  |  |
|----------------------------------|--|
| 1. Power supply / Emergency stop | 7. Battery level indicator                           |
| 2. Choke                         | 8. Tilt warning light                                |
| 3. Function selector switch      | 9. Function activator                                |
| 4. Activation light              | 10. Drive and outrigger deployment activation button |
| 5. Outriggers deployed indicator | 11. Function controller                              |
| 6. System malfunction indicator  | 12. Start  |

**352 Mobile vertical boom lift (3A)**

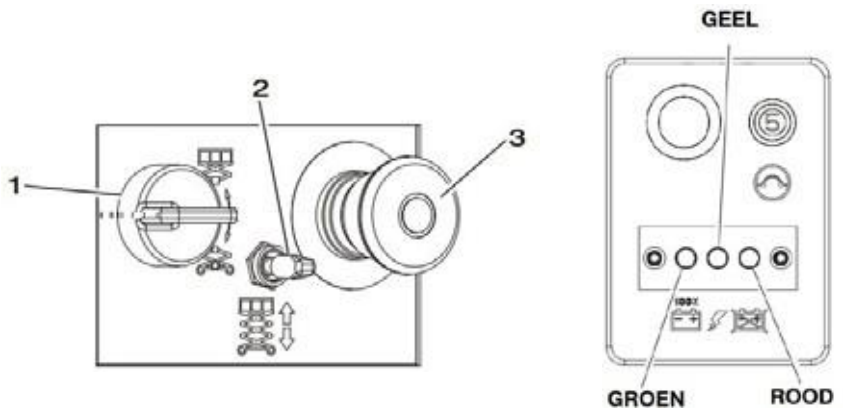

- |                                    |                                     |
|------------------------------------|-------------------------------------|
| 1. Control switch                  | Green = Battery fully charged       |
| 2. Raise and lower platform switch | Yellow = Battery is charging        |
| 3. Emergency stop switch           | Red = Battery not charging properly |

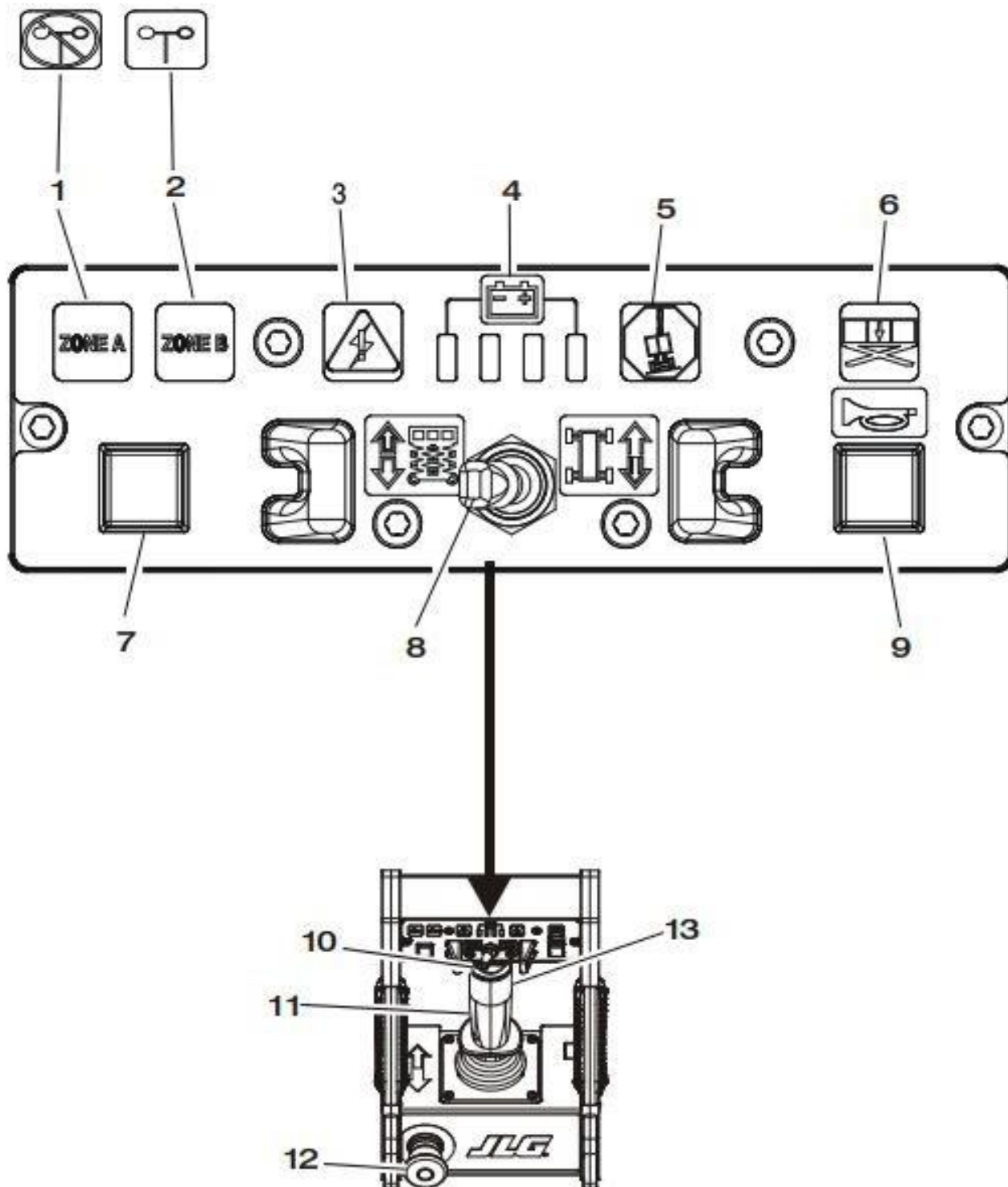

- |  |                               |
|--|-------------------------------|
| 1. Inside (CE) Capacity Zone A (ANSI)  | 8. Lift/drive selector switch |
| 2. Outside (CE) Capacity Zone B (ANSI) | 9. Horn                       |
| 3. System failure                      | 10. Steering switch           |
| 4. Battery charge indicator            | 11. Controller                |
| 5. Tilt indicator                      | 12. Emergency stop switch     |
| 6. Overload indicator                  | 13. Activation button         |
| 7. Capacitance selector                |                               |

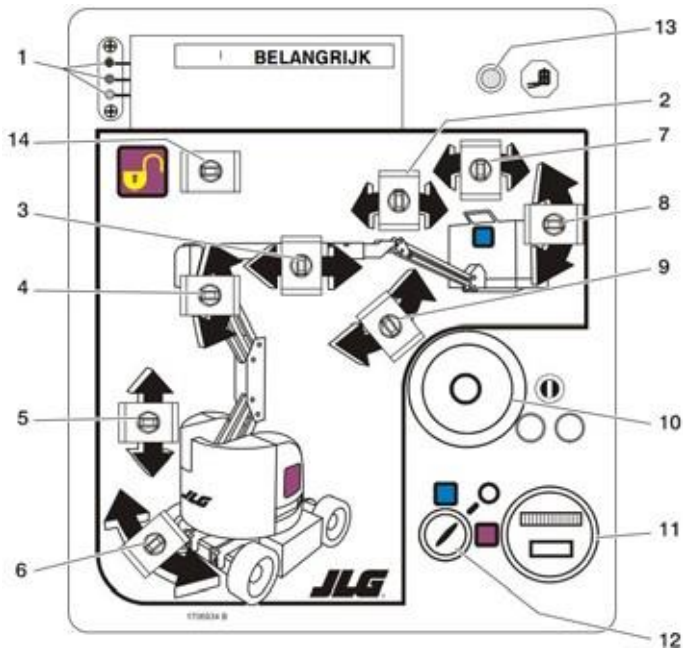

- |                     |                                   |
|---------------------|-----------------------------------|
| 1. Battery status   | 8. Level platform                 |
| 2. Swivel jib       | 9. Raise jib                      |
| 3. Retract-extend   | 10. Power supply / Emergency stop |
| 4. Raise main boom  | 11. Battery status / hour counter |
| 5. Raise lower boom | 12. Platform / ground selector    |
| 6. Swivel           | 13. Platform overload indicator   |
| 7. Rotate platform  | 14. Activate function             |

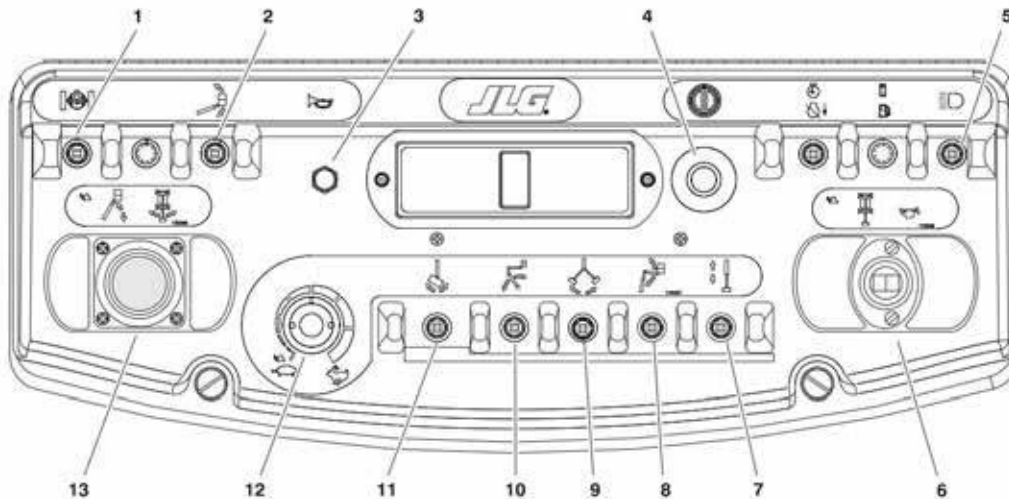

- |                                  |                              |
|----------------------------------|------------------------------|
| 1. Limited slip differential     | 8. Jib                       |
| 2. Override platform auto-level  | 9. Swivel jib                |
| 3. Horn                          | 10. Raise lower boom         |
| 4. Power supply / Emergency stop | 11. Rotate platform          |
| 5. Lights                        | 12. Function speed           |
| 6. Driving and Steering          | 13. Raise - swivel main boom |
| 7. Retract-extend                |                              |



## Summary of key controls

### Horn:

All EWPs are equipped with a horn, consisting of a push button that activates an audible warning system.

### Power- Emergency stop switch:

A red, mushroom-shaped switch with two positions that supplies power to the machine when it is pulled up (turned on). When it is pressed down (off), the power to the machine is switched off.

### Platform/ground-level control switch:

The ignition switch used to switch on the control console has three positions. A neutral position (0), a platform control position, and a ground-level control position.

## Safety devices

### Position limiters:

All movable parts of an EWP must be fitted with a position limiter. When a certain movable part reaches maximum extension or retraction, any further movement in the same direction is automatically blocked. After reaching this position, the part in question will only be able to move in the opposite direction.

Never override these safety devices!

### Load moment limiter:

EWPs capable of lateral outreach feature load moment limiters, which put a limit on the instability of the EWP to prevent it from tipping over. The load moment limiter is activated when the maximum working load is exceeded. Again, this will block all movements in the same direction and will only allow movement in the opposite direction to reduce the machine's envelope.

### Tilt protection (Gyroscope):

If an EWP is too tilted for whatever reason, the machine is not switched off, but will emit an acoustic signal.

It will virtually always be possible to hear this signal from the basket

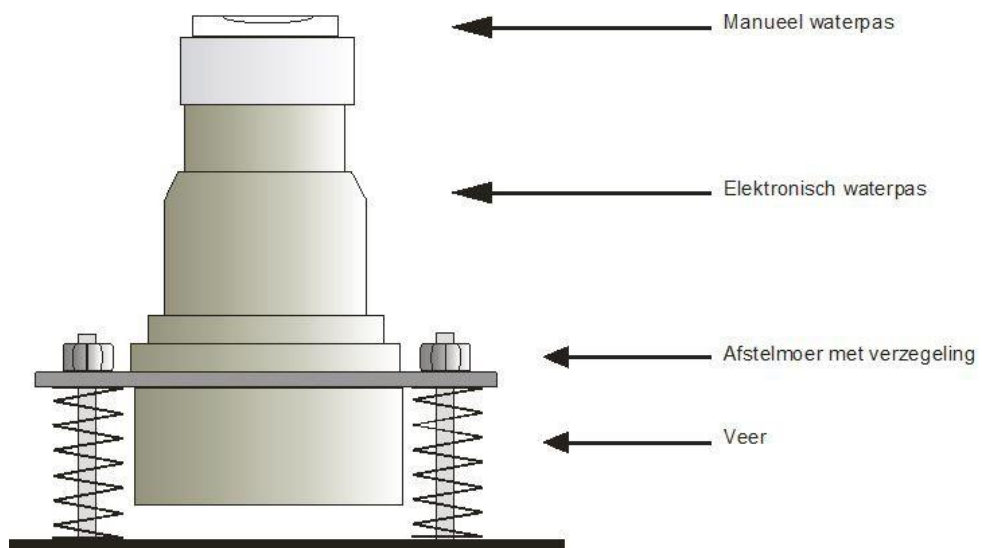

### Drive limiter

On EWP's that can travel with a raised basket, the maximum speed must automatically be limited when the basket is raised to a certain height. This maximum speed differs from one EWP to the next.

## 3.7

### Personal protective equipment

Working with an EWP comes with various specific risks. Despite the fact that the platform of an EWP is always fitted with a handrail, there is a risk that users may be thrown out of the basket or fall over the handrail.

#### This may happen in the following situations:

- Driving over an uneven surface with the basket extended
- Driving over obstacles
- Collisions
- Leaning too far over the handrail of the basket while carrying out work
- When an EWP is driven on and off a vehicle used to transport it
- When tilting the basket or due to a technical malfunction.
- The EWP sinking into the subsurface.

In all the above cases, the person working with the EWP must stay within the confines of the basket. There is only one solution for this: a short lifeline, without a shock absorber to prevent the person working on the platform from toppling over the handrail, as described in Health and Safety Data Sheet 17 (AI17). *Section 8.9.3 lifelines on elevated work platforms*

Exception 1: Fall protection cannot be used because the attachment point does not meet the requirements of NEN-EN280. In other words, the attachment point is not strong enough, which would mean that if a person were to fall from the basket, this may jeopardise the overall stability of the EWP due to the forces produced by arresting the fall of the person in question.

i

#### NOTE

**If the decision is made not to use fall protection, the employer of the person operating the EWP will have to carry out a Risk Inventory & Evaluation demonstrating that there is no risk of falling. In addition, the user manual of the relevant EWP always takes precedence. In a nutshell, you are not always obliged to use a harness with a fall protection device. Do keep in mind, however, that this only applies if a thorough RI&E has been drawn up, and that the user manual of the relevant EWP always takes precedence. This means that employers are obliged to make the right, suitable resources available to their employees, as laid down in Article 5 of the Working Conditions Act: Identification and Evaluation of Risks, and in Article 7.3 of the Working Conditions Decree: suitability of work equipment.**

### So what fall protection do you need when working with an EWP?

In this case, fall protection means a positioning belt, which must be used as per the instructions provided in the user manual of the EWP in question. This fall protection consists of a short lifeline with a safety harness, which will ensure that people in the basket can never fall over the handrail. If the user manual of the EWP does not prescribe a fall protection device, the employer must carry out an RI&E to determine whether fall protection is necessary. Note: The use of a fall arrest system with shock absorber is not permitted. According to the prEN280 standard, the attachment point in the basket would not be strong enough, should someone fall from the basket. This can jeopardise the overall stability of the basket of the EWP. Occupational Health and Safety Data Sheet 17 (AI17) *Section 9.1.1.*

i

#### NOTE

**Make sure to wear a properly fitting, approved safety harness. A safety harness that does not fit properly can restrict the circulation of blood within just 20 minutes of a fall, potentially leading to serious injury or death. Using a sound lifeline is equally important. If the lifeline is too long, very large forces may be exerted on the EWP after a fall, causing the EWP to tip over (the longer the lifeline, the higher the fall velocity).**



#### The attachment point of the lifeline

Let's be very clear: the edge of the basket is **not** the right place! The manufacturer of the EWP will often indicate the best attachment point in the manual or with an icon.

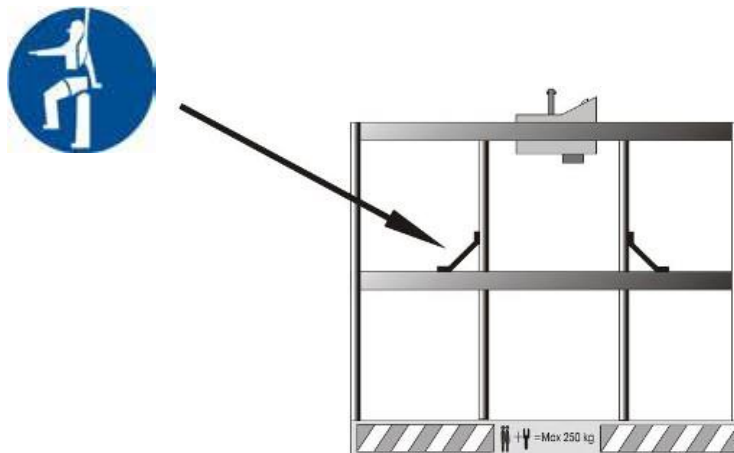

**Emergency procedure**

In an emergency, e.g. in the event that the drive system malfunctions, it must still be possible to lower the basket.

This must be possible even if the standard drive system does not work, e.g.

- From the floor, using a manual pump to make hydraulic oil flow back into the reservoir or with the emergency power switch.
- From the basket, using an emergency switch connected to the battery or an emergency battery.

Different EWP's may have different emergency procedures. Always follow the specific instructions for the EWP you are working with. These instructions must be present on the machine.

**THE EMERGENCY PROCEDURE MUST BE CHECKED EVERY DAY BEFORE STARTING WORK.**

---

**i**

**NOTE**

**Never use the emergency controls for normal operations. If you do, you run the risk of draining the emergency battery!**

## 4. Drives and mechanisms

4.1

### Brakes

Mechanical drive units equipped with a brake must meet a number of conditions:

- The brakes of an EWP must always be engaged, except for when it is moving forwards or backwards.
- The parking brake must be applied automatically in the event that the drive unit should fail.
- The brakes must never be deactivated, except in the case of an emergency procedure or when towing.
- When travelling, the brakes must not be applied so quickly that the EWP may tip over.
- It must be possible to brake smoothly and without any shocks. This can be done by handling the variable drive joystick properly. Note: the EWP will not brake smoothly in the event of an emergency stop, as all functions will be stopped immediately.

4.2

### Drive units

EWPs are driven by an internal combustion or electric motor, depending on where they are used. Material-handling equipment used to lift heavy weights will often be fitted with a combustion engine. Indoors or in poorly ventilated areas, vehicles with electric motors are preferred.

The following types of drives are used:

- Diesel engine;
- Petrol engine
- Electric motor with traction battery
- Hybrid drive
- Pneumatic drive

4.3

### Diesel engine

These engines are only found in large elevating work platforms, as one of their major disadvantages is that they emit soot. Incomplete diesel combustion produces soot particles, which is why diesel-powered EWPs cannot be used in the food and beverage industry or in poorly ventilated areas. Soot emissions can be limited by installing a soot filter, which is mandatory nowadays.

#### 4.3.1

##### **Refuelling diesel vehicles**

Diesel vehicles must be refuelled in the open air above a non-permeable floor. Smoking and naked flames are prohibited while refuelling diesel.

Advantages and disadvantages of diesel engines.

##### **Advantages:**

- + Robust
- + Large range
- + Fuel price  
(red agricultural diesel)

##### **Disadvantages:**

- Produces exhaust gases
- May only be used outdoors
- Engine noise

#### 44

##### **Petrol engines**

Petrol engines have fallen out of favour, because of:

- Harmful exhaust fumes
- Fuel price

Petrol engines are only used in slightly smaller EWPs.

#### 45

##### **Electric motor**

In poorly ventilated areas, electric vehicles are preferred. Electric motors not only power the machine-handling equipment, but also the oil pump and power steering system. Electric motors are powered by a traction battery.

##### **Traction batteries**

Traction batteries convert chemical energy into electrical energy and consist of 2-volt power cells. The number of cells in the battery determine its capacity. These cells are filled with lead and sulphuric acid, a highly corrosive liquid.

##### **Charging traction batteries**

Charging traction batteries is important, because when they are not used until empty, their technical service life is shortened significantly. In addition, their capacity will decrease, as they become "lazy".

Traction batteries should preferably be recharged when they only have 10% charge left.

The most accurate way to measure the charge status of a traction battery is with the aid of an acid weigher, which is used to measure the specific gravity (s.g.) of the liquid inside the battery.

### Charging area

Traction batteries should be charged in rooms or areas without any naked flames and other actions that may produce sparks, e.g. welding and grinding, are strictly forbidden. When a traction battery is recharged, the liquid inside it is set in motion, producing hydrogen gas. Hydrogen is highly explosive and one spark is all it takes to cause an explosion. Hydrogen levels of 4% and higher present an explosion hazard. Therefore, the charging area must be well ventilated and meet all requirements set by the government.

At least the following materials must be present in the charging area:

- Bottle of eyewash or eye bath;
- Fire extinguisher;
- Extraction unit;
- PPE;
- Absorption granules;
- Soda.



#### **CAUTION**

**Neutralise any spills with soda.**

When working on the traction battery, use the appropriate personal protective equipment:

- Acid-resistant glasses or face mask;
- Acid-resistant gloves;
- Acid-resistant apron.



#### **CAUTION**

**Always wear long-sleeved clothing when working with a traction battery.**

### Weighing acid

As the battery charges and discharges, the specific gravity (grams per cm<sup>3</sup>) of the liquid within it will increase or decrease. The particle density of the liquid increases when the battery is charged, so the liquid becomes “heavier”). You can measure the specific gravity of the liquid with an acid weigher. There is a scale on the stem of the float, on which you can find the specific gravity. Measuring the specific gravity of the liquid inside a traction battery lets you determine its remaining charge. In other words: it indicates whether the battery needs to be charged or not.

#### 4.5.1

##### **230 or 400 volt power**

The electric motors in these types of EWPs are connected straight to the mains, which means that all motors run on 230 or 400 volts. These drive units are only used on static EWPs, such as trailer-mounted lifts. When moving the EWP, make sure to disconnect the power cable! The advantage of this type of EWP is that there is no limit to the number of hours of continuous operation, whereas EWPs powered by a traction battery must be recharged regularly.

i

##### **NOTE**

**The EWP must be equipped with a main switch that can be used to power down the entire electrical system at once. This switch must be switched off when the work is done.**

#### 4.6

##### **Hybrid drive**

The hybrid system is a new type of drive used in EWPs based on a combination of a combustion engine and an electric motor, just as in passenger cars. There are two different kinds of hybrid systems: serial and parallel.

#### 4.6.1

##### **Serial hybrid**

In a serial hybrid drive, a petrol or diesel motor powers a generator that, in turn, powers the electric motor. These combustion engines only consume about 2.5 litres of diesel per hour, which is about half the amount used by a conventional combustion engine. On top of that, it needs half as much maintenance.

#### 4.6.2

##### **Parallel hybrid**

Some EWPs feature parallel hybrid drives. This type of hybrid drive lets the user select which drive type to use: the combustion engine, the electric motor, or a combination of both.

#### 4.7

##### **Pneumatic motors**

Only used to drive the lifting system on small EWPs.

##### **Advantages and disadvantages of pneumatic motors**

###### **Advantages:**

- + Simple system
- + Can also be used in explosive environments (EXPROOF)

###### **Disadvantages:**

- Low power
- Risk of freezing
- Sensitive to dirt



## 4.8

### Hydraulic system

There are some minor differences between the various hydraulic drive and lifting systems used in the various types of EWP's, but they are all the same in principle.

The main advantage of a hydraulic system is that it only requires relatively little pressure to deliver a significant amount of force.

#### Types of hydraulic cylinders.

There are two types of hydraulic cylinders:

- Single-acting cylinder
- Double-acting cylinder

## 4.8.1

### Pressure relief valve or overflow valve

Upon reaching maximum extension, overpressure occurs in the system, which means the pressure in the pipelines and cylinders is too high. The hydraulic system usually features a pressure relief valve for protection. In case of overpressure, this valve will allow oil to flow back to the tank, while ensuring the pressure in the cylinders remains the same.

## 4.8.2

### Lowering safety valve or lowering limiter

If the pressure in the lifting mechanism is lost due to a ruptured pipe or hose, the lowering safety valve causes the booms to descend slowly and gradually. Without this limiter, the boom would fall down at high speed.

### i

#### NOTE

When loading the basket at height, exercise great care. The manufacturer's instruction manual will specify the maximum weight to be taken on board the basket.

**NEVER EXCEED THE MAXIMUM PERMITTED LOAD**

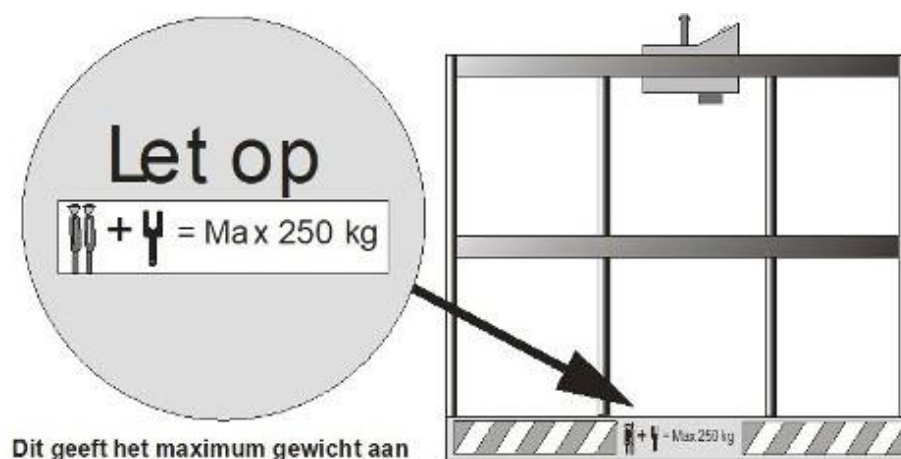

## 5. Stability and Safety

5.1

### Stability

The stability of an EWP must be guaranteed in all situations during normal use: regardless of whether it is loaded or unloaded and regardless of the position and movements of the basket.

#### 1. Stability moment

This moment has a stabilising effect on the EWP.

#### 2. Tilting moment

This moment causes the EWP to tilt and is affected by the mast length and the weight of the basket.

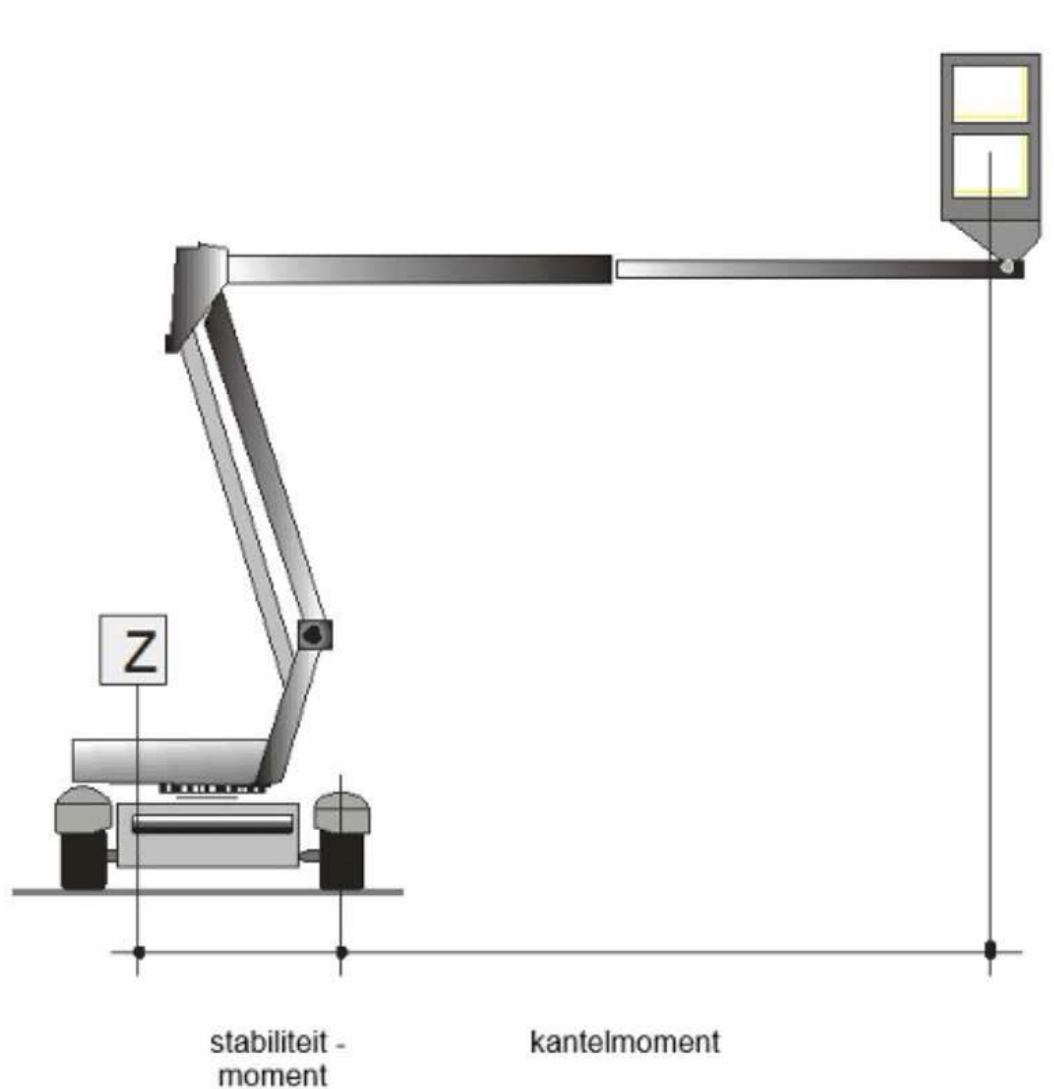

The tilting moment must always be less than the stability moment.

In the worst case, the ratio of the tilting moment to the stability moment may never exceed:

- No outriggers deployed: 66.6%
- Outriggers deployed: 80%

This includes the effects of the wind.

The stability of an EWP depends on several factors:

- The subsurface and setup
- The height
- Load size and envelopes
- The wind

## 52

### Subsurface and setup

Before using an EWP, it must be set up horizontally, as the risk of tipping increases as the platform is raised higher.

All EWPs must therefore be equipped with sufficient supports, such as blocked wheels, outriggers, or stabilisers.

EWPs must always be set up in such a way that they cannot tip over because of sliding, sagging, or rotating supports while in use. When using outriggers and stabilisers as supports, these may not unintentionally budge, even if they are operated manually. The footplates must be self-adjusting (maximum 10° tilt).

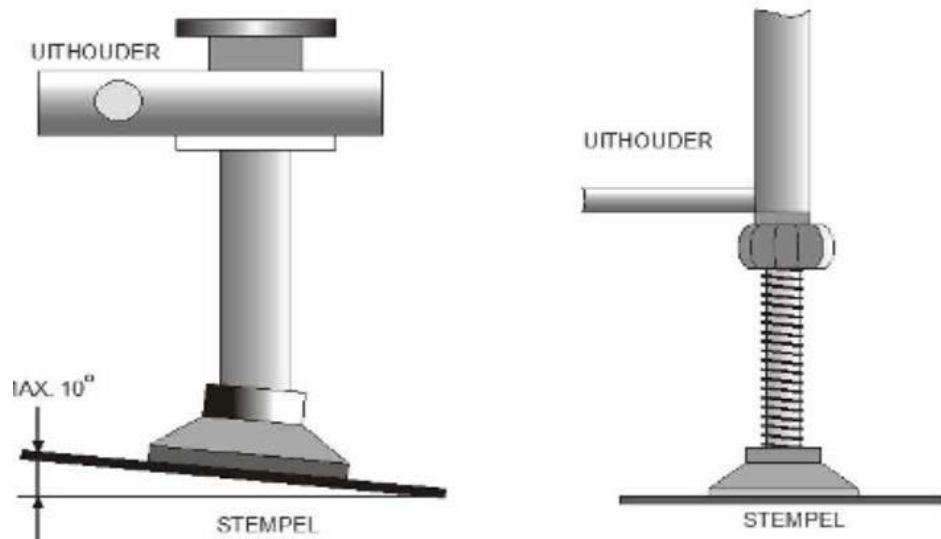

i

#### NOTE

If the subsurface does not have a sufficiently high load-bearing capacity, the stability of the EWP must be increased by positioning large outrigger plates under the supports.

### 5.2.1

#### Wheels

When using the wheels of an EWP as supports, all wheels must bear part of the load and be secured on at least one axis. If this is not possible, the wheels cannot be considered reliable supports.

The use of pneumatic tyres is only permitted on EWPs with outriggers. Tyres that are flat or overly soft will have a negative impact on the stability of the EWP. EWPs that do not have outriggers must be fitted with solid or full-foam tyres or solid rubber tyres.

The maximum wheel load is indicated in Newton, which means that the pressure exerted on the ground or floor is also important. 750 N is equal to 75 Kg.

### 5.3

#### Height

As mentioned earlier, the risk of tipping increases as the platform is raised higher.

Scissor lifts, for example, are very instable when subjected to lateral forces. If these EWPs are not set up horizontally, the danger of tipping over will increase as the platform is raised.

If the EWP is set up at a 10 cm tilt, at a height of:

- 10 metres, the work platform will be approx. 60 cm off the centre line
- 20 metres, the work platform will be approx. 120 cm off the centre line.

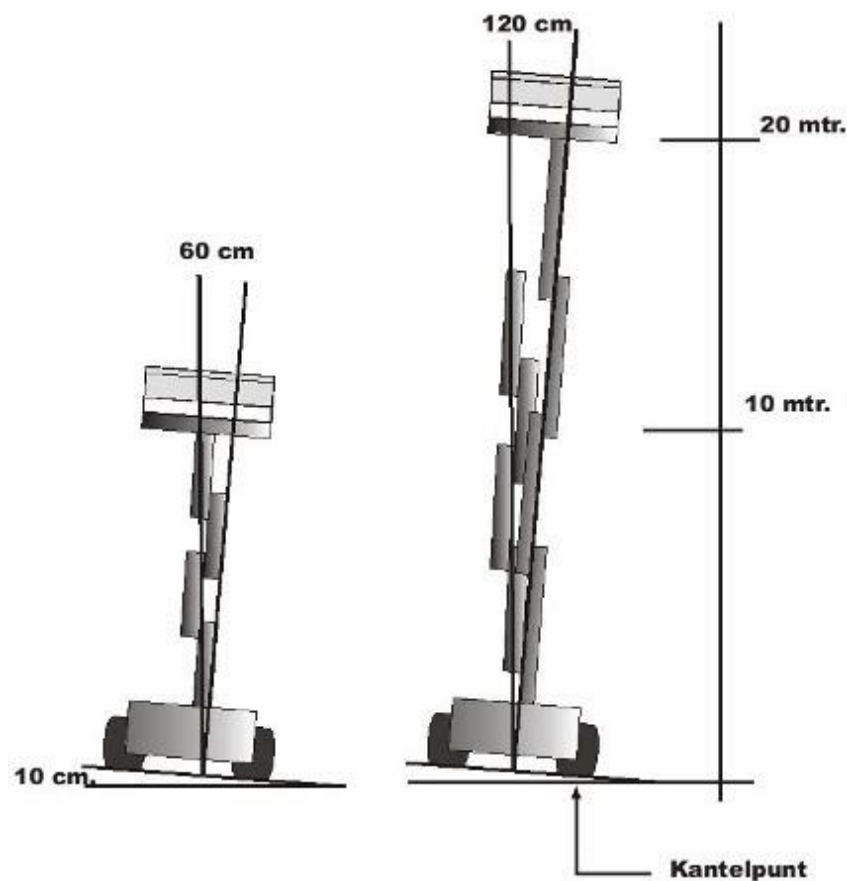

EWPs always tip over at the furthest support point, the so-called “tipping point”. The tipping point may be one of the wheels, but if outriggers or stabilisers are used, these will become the tipping point. Some EWPs have built-in tilt protection devices. It is advisable to lower the basket as much as possible when driving an EWP. Crawler track lifts may seem to be robust and stable, and this is certainly true when the load of the lift is distributed evenly across the entire crawler track. However, when a crawler track lift drives over a rail, threshold, or other obstacle, it is at risk of tipping over, which may result in the operator being thrown from the basket, especially when the basket is in the air.

i

### CONCLUSION

**The more level an EWP is set up, the more stable it will be at height!**

54

### Load size and envelopes

The envelope of a telescopic boom lift is the horizontal distance between the centre line of the turntable and the centre line of the basket. A telescopic boom lift has a variable envelope, with the working load depending on the envelope.

If the SWL changes along with the envelope, the manufacturer must indicate this with pictograms or state it clearly in the manual. This does not apply to the somewhat smaller EWPs. If the envelope protrudes far beyond the undercarriage, there is a chance that the SWL of the EWP will drop. This must be indicated in an envelope chart.

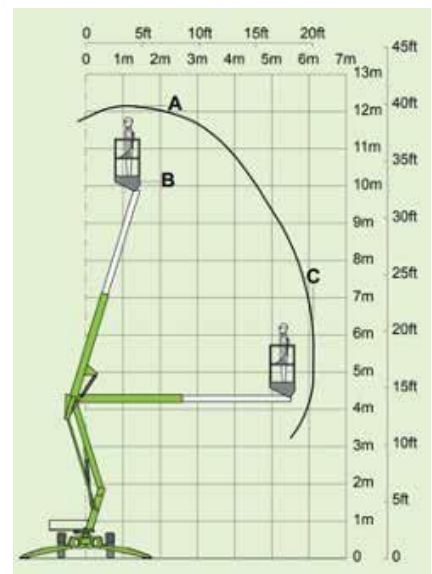

**PAY CLOSE ATTENTION TO THIS WHEN SELECTING EWPs**

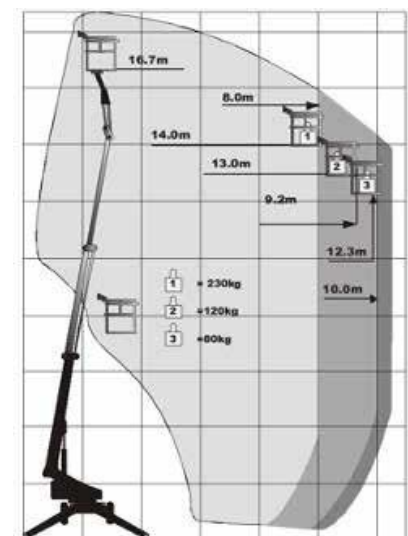

Verandering in gewicht

### Wind and its effects

The wind also affects the stability of EWPs, as the wind exerts horizontal or lateral forces to any surface it hits. This can cause an EWP to tip over or parts to break off.

Wind speeds can be measured with an anemometer. This indicates the wind speed in metres per second.

Wind forces are often indicated in metres per second (m/s). The table below details the various Beaufort wind forces, their description, their speed (in m/s), and their specifications.

Beaufort	Description	m/s	Specifications
0	Calm	0.0 - 0.2	Smoke rises vertically or almost vertically.
1	Light air	0.3 - 1.5	Direction of wind shown by smoke drift.
2	Light breeze	1.6 - 3.3	Leaves rustle, wanes moved by wind.
3	Gentle breeze	3.4 - 5.4	Leaves and small twigs in constant motion.
4	Moderate breeze	5.5 - 7.9	Raises dust and loose paper.
5	Fresh breeze	8.0 - 10.7	Small trees in leaf begin to sway, crested wavelets form on inland waters.
6	Strong breeze	10.8 - 13.8	Large branches in motion, whistling heard in telegraph wires.
7	Near gale	13.9 - 17.1	Whole trees in motion.
8	Gale	17.2 - 20.7	Breaks twigs off trees.
9	Severe Gale	20.8 - 24.4	Twigs break off, slates removed.
10	Storm	24.5 - 28.4	Trees uprooted.
11	Violent storm	28.5 - 32.6	Wide-spread damage to forests and buildings.
12	Hurricane	32.6 - and >	Catastrophic damage.

*Wind force is a dynamic force that can constantly change direction and force.*

#### Other dynamic forces include:

- Braking forces: the braking force exerted by wheels to which brakes have been applied on the driving surface.
- Horizontal transverse forces: The boom of an EWP may be subjected to horizontal forces when its occupants drill in an adjacent structure, for instance.
- Forces applied by platforms and stairs/ladders: These two points must be designed to withstand a movable concentrated load.
- Forces on handrails: Handrails are designed to withstand a horizontal, movable concentrated load.

## 5.5

### The basket

The basket must be a safe place to work and must meet certain requirements,

such as:

- The basket must be accessible via a safe route, e.g. a ladder on the side of the undercarriage
- The basket must be equipped with a non-slip floor
- It must be possible for rainwater to drain
- The basket must be free of damage and deformations
- The basket must have a handrail around its perimeter at a height of 1 m
- The basket must have a knee rail around its perimeter at a height of 0.5 m
- The basket must have a foot rail around its perimeter at a height of 0.10 m
- Have a self-closing entrance gate

People may only enter and leave the basket when it has been fully lowered. The shielding may be partly removed to make it easier to access the basket, but it must be put back in place properly before using the EWP.

**Baskets can only hold a limited number of people.**

The minimum internal dimensions of a basket are:

- A basket for 1 person: 0.60 x 0.90 metres.
- A basket for 2 people: 0.60 x 1.20 metres.

With some large scissor lifts, the basket can hold more than 2 people. This must be stated expressly on the lift in question.

---

i

#### NOTE

**The basket must also be inspected on a daily basis and subjected to an expert checkup once a year.**

## 5.6

### Emergency situation

In the event of an emergency, it must be possible to lower the basket to the lowest position from the ground at an adjustable speed (see emergency procedure). This is why it is always recommended to man EWPs with a crew of two, with one person in the basket and one person on the ground.

**The person on the ground has the following tasks:**

- Lowering the basket in case of an emergency.
- Preventing unauthorised persons from operating the control panel. This can lead to dangerous situations.
- Prevent passers-by from walking under the basket.

---

i

#### NOTE

**When using mobile control panels, make sure that the panel is positioned correctly, as the controls may otherwise be inverted. There is always a switch at the bottom to switch between basket control and ground-level control.**

### Cordoning off the work area

Measures must be taken to ensure that passers-by cannot walk under the EWP and that the EWP cannot be hit. These measures can include:

#### *Tape barrier:*

This prevents onlookers from walking under the EWP. In some departments, people may only see a tape barrier as a warning and cross the barrier anyway. Please note that the operator of the EWP remains responsible at all times.

#### *Hard barrier:*

These barriers are placed on the road, accompanied with traffic signs, when an EWP is at work on or over a public road. Please note that rules on business premises may differ from one company to the next. Make sure that you are familiar with the company rules.

### Working near electrical installations

EWPs must not come too close to electrically live installations, because not all EWPs are sufficiently insulated for this type of work. Only special types of EWPs with insulated baskets are permitted to work in the vicinity of live electrical installations, such as overhead lines.

To prevent electrocution (an electric current passing through your body and resulting in serious injuries or even death), you must keep a safe distance from live electrical installations while working.

#### The minimum safe distances for work are:

- 5 metres for contact lines, such as railways and tramways
- 25 metres for low-voltage lines on wooden masts
- 50 metres for high-voltage lines on steel masts

## 5.7

### **Safety**

According to the Working Conditions Act, the operator of an EWP is responsible for their own actions and the consequences thereof. In practice, this means that the operator will be held liable if they cause an accident with the EWP.

#### In the event of an accident, the operator will have to explain:

- How the accident happened
- Whether they observed all safety measures
- Whether they were authorised to operate the EWP
- How the accident could have been prevented

The EWP in question will also be inspected. If it turns out that the operator was negligent, they may even face criminal prosecution!

On the following pages you will find various safety instructions. Please read these carefully and apply them in practice in order to keep accidents to a minimum.



## 5.7.1

### The law and using EWP's

The following legal provisions apply to users with regard to the instruction on and operation of EWP's:

- EWP's may only be operated by persons 18 years and older. Do not allow unauthorised persons or persons with a fear of heights to operate the basket.
- EWP's may only be operated by persons who are familiar with the controls and who have received sufficient instruction in order to operate EWP's safely.
- The employer is responsible for ensuring that the person operating the EWP is capable of doing so and meets all legal requirements. Specific situations that may arise while using the EWP in the workplace must be clearly discussed with the user. All instructions must be comprehensible and complete.
- Before working with an EWP, the instructions should be read carefully. Not all EWP's are the same. Make sure to read the warning and information stickers on the EWP!
- EWP's must be inspected before starting work. The rental company or owner of the EWP must indicate which elements of the EWP are to be checked and/or serviced by the user. Never work with a malfunctioning EWP.
- The maximum safe working load of an EWP may never be exceeded. Limiter switches may not be disabled. When operating an EWP, make sure to exercise great care and caution.
- Users may only work on the EWP when standing in the basket with both feet on the floor.
- When working with the EWP, it may only be operated from the basket.
- An EWP may never be used as a hoist.
- With the basket raised, EWP's may be used at wind speeds up to and including wind force 6. It may be necessary to stop working at lower wind speeds when working with large parts.
- The basket must be clean and in good condition and the operating instructions must be clearly legible.
- EWP's may not be used in the vicinity of active overhead cranes. If necessary, place a safety lock on the main switch of the crane. If this is not possible, clear arrangements must be made and recorded in writing in the department in question. These agreements can be made on the basis of a risk analysis report.
- If specific instructions have to be given, these may only be given by one person. When working at heights exceeding 25 metres, communication devices, e.g. walkie-talkies, are mandatory.
- When working in the vicinity of unprotected, overhead, live electrical lines, keep a distance of: 5 metres from contact lines for trains, trams, cranes, etc.

## 5.7.2

### Setting up an elevating work platform

- EWP's must be set up level and horizontally. When working indoors: make sure that the floor is clean, even, and free of obstacles, and set up barriers if necessary. When working outdoors: The bearing capacity of the soil must be sufficient.  
If this is not the case, use outrigger pads or duckboards, to prevent the EWP from tipping over.
- You may only enter and exit the basket when it has been fully lowered.
- During the work, the gate to the basket must be closed.
- If there is a risk that someone may walk under the platform, the working area should be cordoned off with tape or fencing. You must also appoint a designated safety person.

573

#### **Working with an elevating work platform**

- While driving, swivelling, and raising and lowering the lifting mechanism, the operator must always keep an eye on obstacles that the basket, lifting mechanism and/or undercarriage may collide with.
- When operating EWP's that can be moved with the basket raised, the driver must have a good view of the road, so that they can always detect collision risks in good time.
- When operating a scissor lift, the extendible work platform must first be retracted before it can be raised or lowered.
- You should never enter or exit an EWP at height, not even from or to an existing, fixed landing.
- The load may not protrude from the basket. Never exceed the SWL.
- An elevated work platform is not a hoist!
- Do not use tools in the basket to get up higher (e.g. a ladder). Do not stand on the handrails. *THIS IS POTENTIALLY LIFE-THREATENING*

574

#### **End of work**

- Drive the EWP to its parking spot
- Lower the mechanism to its lowest position
- Set the controls to neutral and push the emergency stop button
- Switch off the ignition and take the key with you
- Switch off the main switch and shut down the machine
- If necessary, charge the battery

575

#### **Public Road Rules**

- Hard barriers, lights, and signs are mandatory when working on public roads. Always request Rijkswaterstaat or the local municipality to put up barriers.
- Please note: when working in a business park, public road rules, in addition to various extra rules, may apply. Make sure you know those rules.
- EWP's on public roads fall under Art. 1.1 of the regulations for "Slow-moving motor vehicles". In other words, the maximum speed limit is 25 km/h, an SMV sign is mandatory, and the lights must be in order.

#### **General safety stickers**

On the following pages you will find an overview of the general safety stickers and where to find them

# NOTICE

**POSITION VEHICLE & TRAILER ON LEVEL GROUND BEFORE ATTEMPTING TO COUPLE / DE-COUPLE**

**Coupling instructions**







- Depress the trigger on the lever mechanism and lift the handle upwards and forwards.
- Place the unlocked coupling head onto the tow ball and apply slight downwards pressure. The head will automatically lock onto the ball.
- Ensure the trigger has returned to its free position before attempting to tow, and that the coupling head is secure on the towing ball.
- Connect the breakaway cable to the towing vehicle hitch - not to the tow ball itself.
- Connect the lighting plug to the vehicle and check the light functions.
- Raise the jockey wheel to the stowed position and secure for transit.

**De-coupling instructions**

- Apply trailer handbook & chock wheels.
- Lower the jockey wheel to the ground. Disconnect the breakaway cable and lighting plug.
- Operate the handle by depressing the trigger and manually lift the coupling head clear of the towing ball or screw down the telescopic jockey wheel to achieve the same effect.

**Handbrake operation**

- To operate the trailer parking brakes pull handbrake lever upwards and backwards. The spring loaded mechanism will engage and stay in the operated position until reset.
- To disengage the parking brakes, firmly grasp the handbrake lever and pull upwards. Depress the ratchet release button in the end of the handbrake lever and return lever to the functional position.







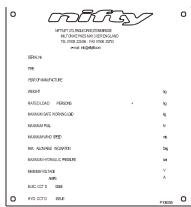

# WARNING

Serious injury may result if all four outriggers / stabilisers are not lowered onto a firm level surface and machine base made level ensuring each supporting foot is taking equal weight with the wheels clear of the ground.



**8**



ITEM	DESCRIPTION	UNIT	VALUE
1	MAXIMUM PLATFORM WEIGHT	kg	1000
2	MAXIMUM PLATFORM WEIGHT	kg	1000
3	MAXIMUM PLATFORM WEIGHT	kg	1000
4	MAXIMUM PLATFORM WEIGHT	kg	1000
5	MAXIMUM PLATFORM WEIGHT	kg	1000
6	MAXIMUM PLATFORM WEIGHT	kg	1000
7	MAXIMUM PLATFORM WEIGHT	kg	1000
8	MAXIMUM PLATFORM WEIGHT	kg	1000
9	MAXIMUM PLATFORM WEIGHT	kg	1000
10	MAXIMUM PLATFORM WEIGHT	kg	1000
11	MAXIMUM PLATFORM WEIGHT	kg	1000
12	MAXIMUM PLATFORM WEIGHT	kg	1000
13	MAXIMUM PLATFORM WEIGHT	kg	1000
14	MAXIMUM PLATFORM WEIGHT	kg	1000
15	MAXIMUM PLATFORM WEIGHT	kg	1000
16	MAXIMUM PLATFORM WEIGHT	kg	1000
17	MAXIMUM PLATFORM WEIGHT	kg	1000
18	MAXIMUM PLATFORM WEIGHT	kg	1000
19	MAXIMUM PLATFORM WEIGHT	kg	1000
20	MAXIMUM PLATFORM WEIGHT	kg	1000
21	MAXIMUM PLATFORM WEIGHT	kg	1000
22	MAXIMUM PLATFORM WEIGHT	kg	1000
23	MAXIMUM PLATFORM WEIGHT	kg	1000
24	MAXIMUM PLATFORM WEIGHT	kg	1000
25	MAXIMUM PLATFORM WEIGHT	kg	1000
26	MAXIMUM PLATFORM WEIGHT	kg	1000
27	MAXIMUM PLATFORM WEIGHT	kg	1000

**9**



**10**



# NOTICE

**READ THIS BEFORE OPERATING THIS MACHINE**  
THIS NOTICE DOES NOT REPLACE THE OPERATING MANUAL WHICH SHOULD BE READ BEFORE OPERATING THIS MACHINE FOR THE FIRST TIME.

**BEFORE USE**

Refer to the operating manual located in the platform and perform the daily maintenance checks routine as required. Read all labels on the machine.

**ACTIVATING THE MACHINE**

- Check all Emergency Stops are set.
- Manual Outriggers:** Select either platform or base control by turning the key switch on the base control station. When the platform key switch must be switched to 'OFF' to operate from the platform.
- Select a power option by turning the selector switch in the platform. (Note: On Scissor machines, 'Battery (B)' is selected and the engine is running, the machine will not start before operation.)
- Hydraulic Outriggers: If the machine is set on the ground or platform control station to 'OFF' position to activate the outriggers.
- If no other power option is already running, the hydraulic control panel will default to battery power (if applicable).
- All Machines: To start the engine see the manual to be used for the engine.
- Check engine: Fuel and hot the 'Idle' button. The 'Start' button must be held in the selected start position and the engine will fire.

**EMERGENCY STOP**

Pushing in an emergency stop will stop all functions and turn the engine off.

**EMERGENCY HAND PUMP**

If the event that the operator falls or the operator becomes incapacitated the booms can be operated by using the hand pump adjacent to the ground controls.

**LOW BATTERY WARNING (Battery model)**

If the alarm sounds and operators become inattentive, the batteries need recharging. Send to engine power or change the machine immediately. (Note: This feature is optional and may not be fitted to the machine).

**TO OPERATE OUTRIGGERS**

- Position the Niftylift on firm, level ground. Never work with base angles or adjust to any slope.
- Position the Niftylift, bearing in mind range or boom movement so that any over head obstructions or power lines are clear.
- If the load bearing capacity of the ground is in any doubt apply outriggers. Check ground and condition of area using appropriate cones, banners and signs.
- Stable: Lock: Ready: Stand.
- To operate the outriggers refer to the details on the outrigger control station (if applicable) or beside the outriggers (if fitted).

**ALWAYS: NEVER SCOPE FULLY EXTENDED, OUTRIGGERS, HITCHES, RETRACTORS OR BOOMS THE OUTRIGGERS IN ANY WAY.**

**TO OPERATE BOOMS**

To operate from ground or platform:

- Press and hold the green power button (if fitted).
- Slowly move the desired control according to the direction on the control panel.

**AFTER USE**

- Return the machine to the stowed position.
- Turn the key switch to the 'OFF' position.
- Remove all keys. Check wheels.

**15**



# DANGER

**READ THIS BEFORE OPERATING THIS MACHINE**  
THIS NOTICE DOES NOT REPLACE THE OPERATING MANUAL WHICH SHOULD BE READ BEFORE OPERATING THIS MACHINE FOR THE FIRST TIME.

**YOU MUST NOT OPERATE THIS MACHINE**

**HAZARD**

Only those who have been trained in the safe operation of this machine. Training includes complete knowledge of the safety and operating instructions contained in the manufacturer's manual, your employer's work rules and applicable government regulations.

Inspect the machine before use to be sure it is operating correctly.

**ELECTROCUTION HAZARD**

**THIS MACHINE IS NOT INSULATED**

Do not touch live or exposed parts. Do not touch machine only, rock and steel, and electrical lines nearby.

This machine does not provide protection from contact with live parts.

You must maintain clearance between any part of the machine or its conductors and any device, live or exposed carrying over voltage.

**EXPLOSION HAZARD**

Do not start the Niftylift if you can smell gasoline, kerosene or diesel fuel.

The engine must be shut down until the fuel tank is empty. Fueling and refueling charging must be done in a well-ventilated area free of any open flame or other sources of ignition.

Do not use the Niftylift in areas where there is a risk of explosion.

**HAZARDOUS SUBSTANCES AND ENVIRONMENTS**

The Niftylift is not a level of hazardous substances such as but not limited to: Benzene, Hexane, Lead, Engine Oil, Antifreeze, LPG, Diesel Fuel, Petrol, Engine Oil, Grease, Calcium Chloride, etc.

Caution and maintenance should be observed when the machine is in operation. Only trained personnel should carry out maintenance on the machine, ensuring all lines are protected from electrical, heat and mechanical hazards.

**DAMAGED OR MALFUNCTIONING MACHINE**

Do not use a damaged or malfunctioning machine. If the machine malfunctions during operation or the

**STABILITY**

The machine must be on a firm level surface before using the booms.

Do not use the machine on a slope or on a surface with a slope exceeding 10%.

Always secure the platform capacity load. Do not exceed capacity. Do not use the machine on a slope exceeding 10%.

Do not use the machine on a slope exceeding 10%.

Do not use the machine on a slope exceeding 10%.

**SELF PROPELLED**

Do not attempt to climb or descend the machine.

Do not attempt to climb or descend the machine.

Do not attempt to climb or descend the machine.

Do not attempt to climb or descend the machine.

**COLLISION HAZARD**

Heat protection must be worn.

Operation with rotating machinery can result in serious injury.

Do not attempt to climb or descend the machine.

Do not attempt to climb or descend the machine.

Do not attempt to climb or descend the machine.

**RESTRAINT**

All personnel on the platform must wear a body belt with a lanyard attachment secured to the designated point.

Do not drink, or use any other substance that could impair your ability to operate the machine.

Do not attempt to climb or descend the machine.

Do not attempt to climb or descend the machine.

**PLATFORM OVERLOAD WARNING**

If the machine is fitted with an overload alarm, which activates at 100% of the rated load, removal of excess load is essential to avoid damage to the machine.

**17**

# DANGER

Death or serious injury may result if emergency stop switch is disabled, blocked or inoperable?

**20**



**18**

# DANGER

IF OVERLOAD ALARM ACTIVATES, ALL FUNCTIONS WILL HALT. REMOVE EXCESS LOAD IMMEDIATELY IN A SAFE MANNER TO RESTORE FUNCTION.

**19**

# DANGER

IF TILT ALARM SOUNDS, DESCEND IMMEDIATELY AND CHECK OUTRIGGER/STABILISER SETTINGS.

# WARNING

Do not replace without manufacturers consent any components critical to the aerial platform stability with lighter weight components. This includes the engine, batteries, tyres or any other substantial item.

If in doubt contact Niftylift immediately.

**23**



**22**

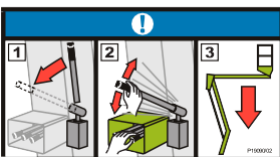

# CAUTION

## MACHINE DAMAGE RISK

To avoid damage to charger/disconnect from mains before using machine.

- Red light means batteries are charging.
- Flashing green light means the charge is equalising.
- Constant green light means batteries are fully charged.

- Read and comply with all safety instructions in the operating manual.
- Before use inspect for any signs of wear or damage.
- Connect to 3-wire grounded A.C. outlet. Use 3-wire grounded extension cord. For additional safety use a trip switch device on the extension cord.
- After connection check charger L.E.D. display to ensure correct operation.

**13**

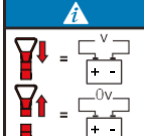

**16**

# NOTICE

**STABILISER IDENTIFICATION**

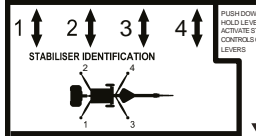

**TO PREVENT UNNECESSARY LOADING ON THE MACHINE USE THE FOLLOWING STABILISER SEQUENCE:**

- DEPLOY FRONT STABILISERS (L&R). L&R CONTACT IS MADE WITH THE GROUND.
- NEXT DEPLOY REAR STABILISERS (L&R). L&R CONTACT IS MADE WITH THE GROUND.
- FINALLY LEVEL MACHINE BASE USING THE FRONT THEN REAR STABILISERS.
- RAISE STABILISERS USING THE REVERSE SEQUENCE.

**25**

# DANGER

HANDBRAKE MUST BE FULLY APPLIED BEFORE TRACTION SYSTEM IS DIS-ENGAGED FROM ROAD WHEELS. RELEASE HANDBRAKE BEFORE DRIVING OR TOWING.

**14**



**26**



**27**

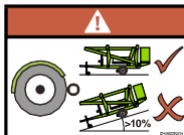

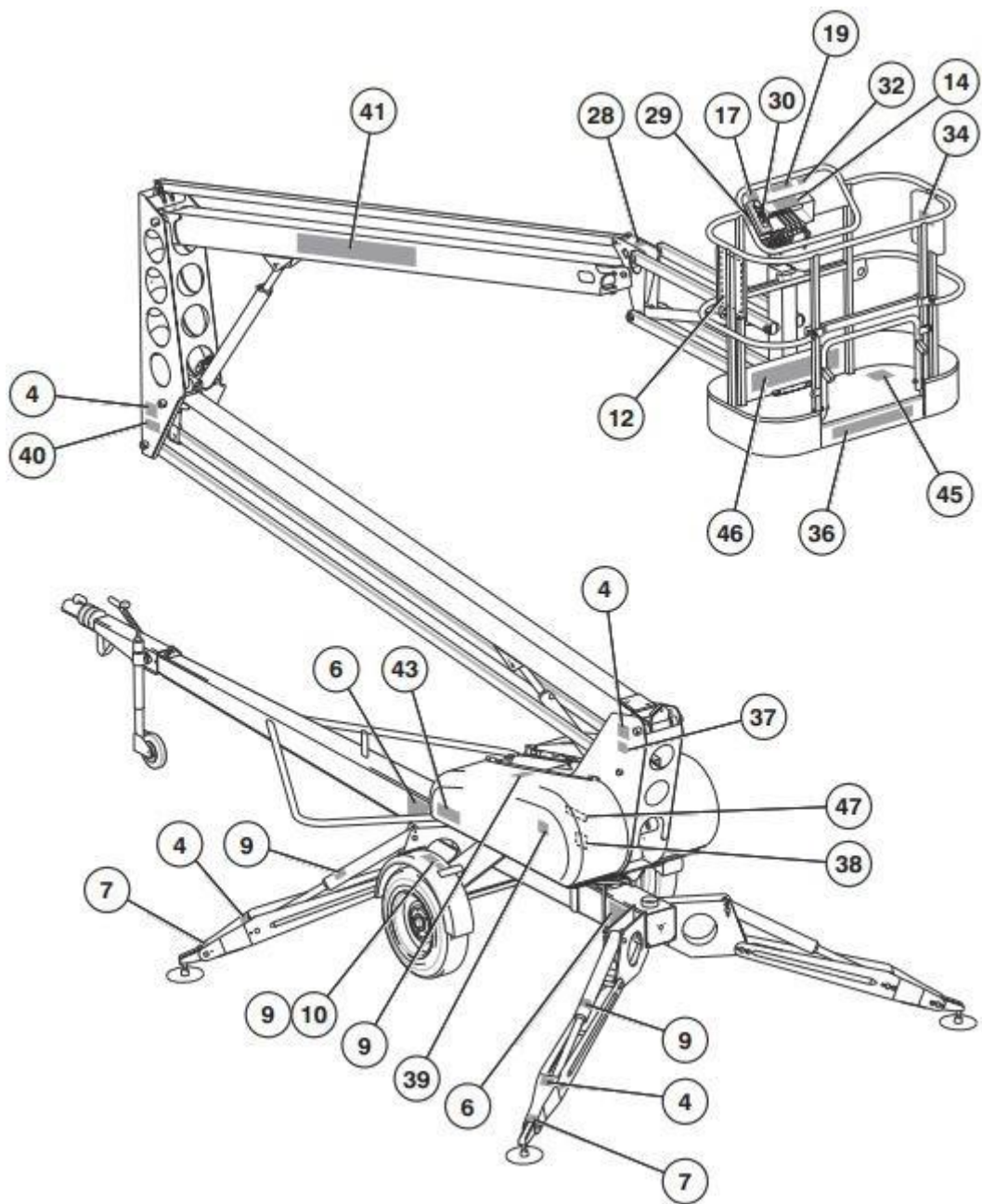

28



29

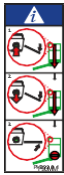

32

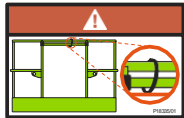

42\*

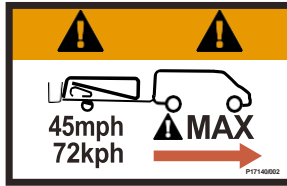

30

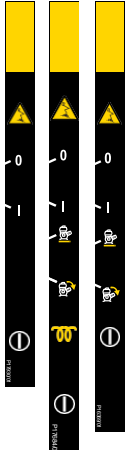

31



43\*



44\*



33

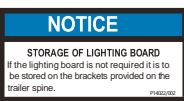

34

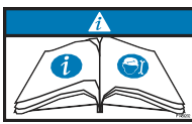

45\*



36

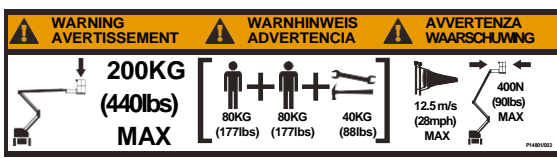

37

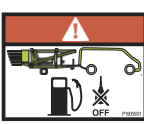

38



46\*



39

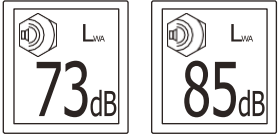

47\*

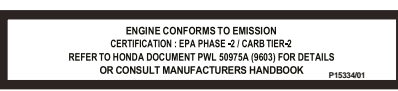

40

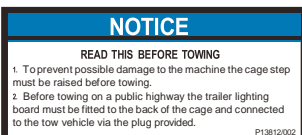

\*TM40 (USA) ONLY

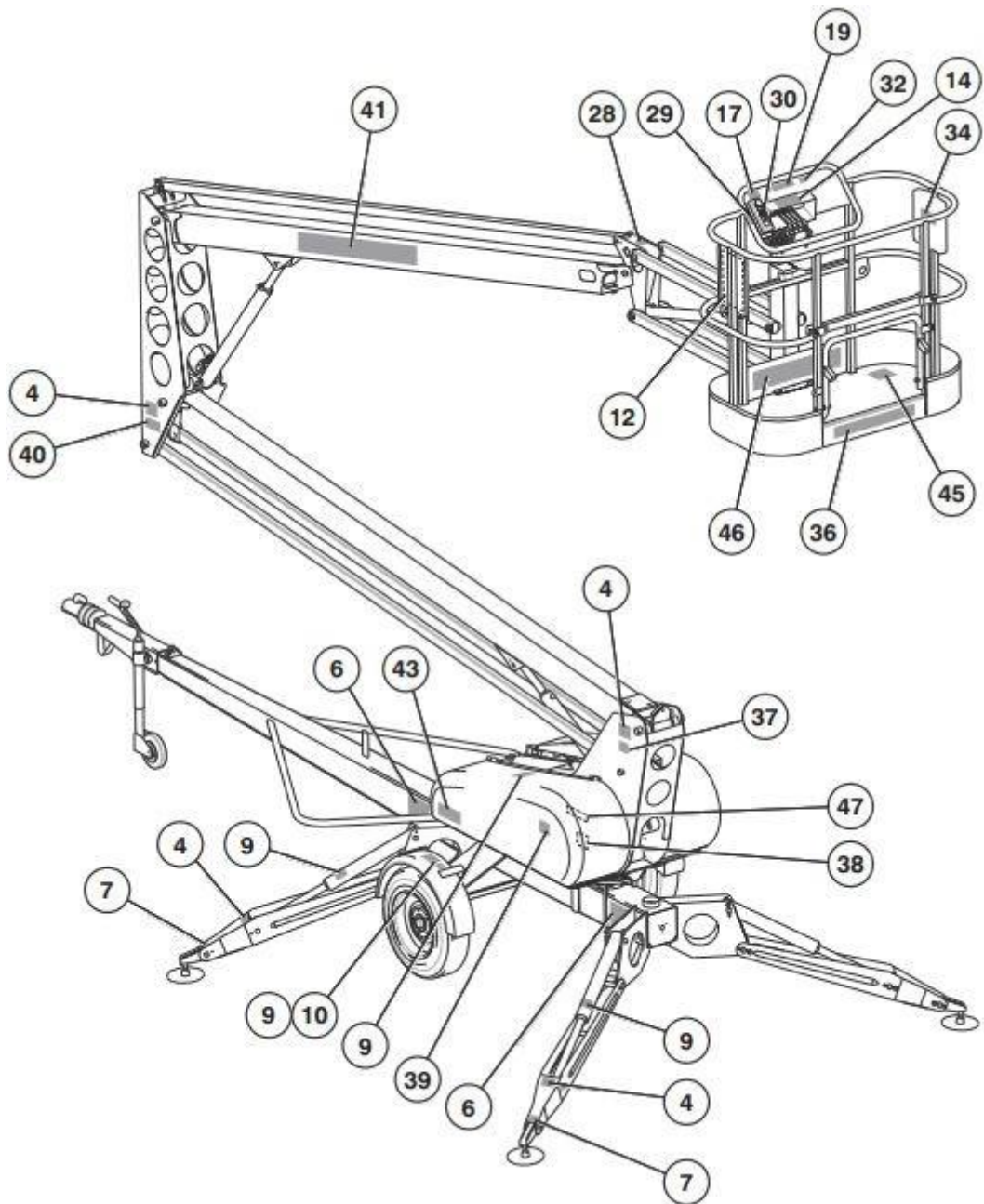

---



---



---



---



---



---



---



---



---



---

---

---

---

---

---

---

---

---

---

---

---

---

---

---

---

---

---

---

---

---

---

---

---

---